



## Operating American Crane Car

The Operating American Crane Car adds heavy duty moving and lifting power to your scale layout. With a die-cast base and a body constructed from sturdy ABS plastic, the authentically detailed crane car is a perfect addition to your O Gauge layout.

The crane car is pre-assembled and easy to operate. Simply follow the directions and diagrams inside.

PLEASE READ BEFORE USE AND SAVE  
[www.mthtrains.com](http://www.mthtrains.com)

The Operating American Crane Car is comprised of two components, the crane car itself, and the cranking tool. Follow the directions below to operate the crane car.

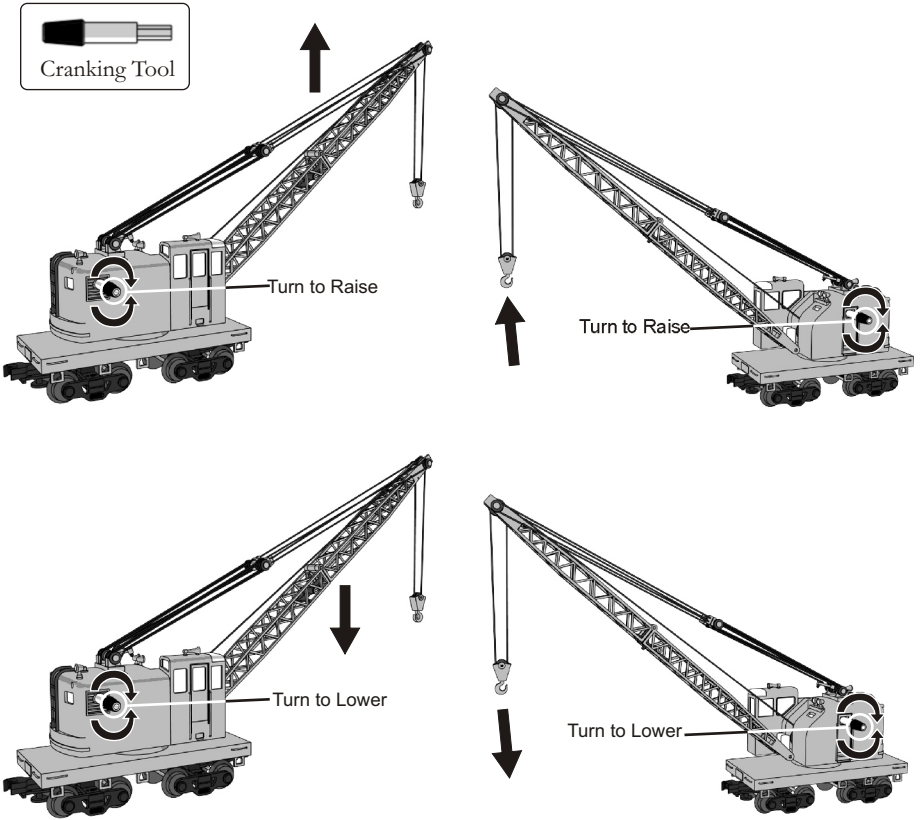

**To raise and lower the boom:** Insert the cranking tool into the hole on the right side of the crane. Turn the tool in either direction to raise or lower the boom.

**To operate the hook:** Insert the cranking tool into the hole on the left side of the crane. Turn the tool in either direction to raise or lower the hook.

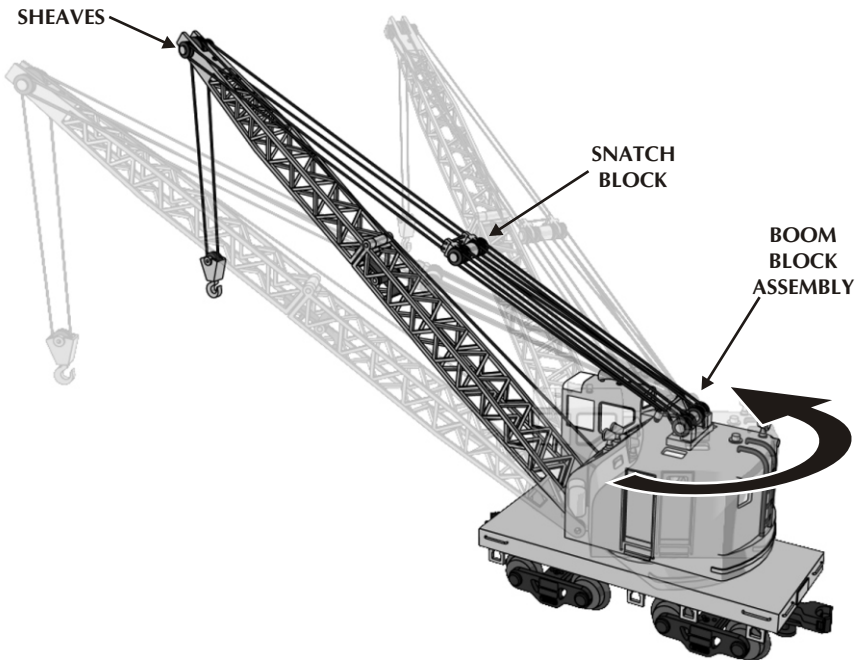

**To rotate the crane body on the base:** Manually turn the crane body in either direction.

**To operate on tight radius track:**

Because this crane has a prototypically long boom, it may have difficulty clearing the accessories and landscape around tight curves. If you do not have a tunnel on your layout, you may find that cranking the boom into its highest possible position will allow the boom to clear trackside accessories and landscape.

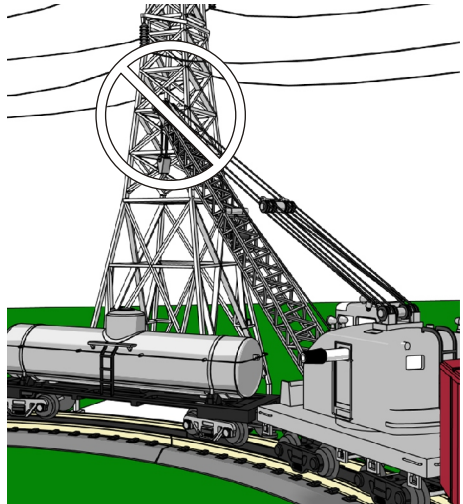

**For those of you who have a tunnel,** we have designed the boom to fold so that the crane can run on tight radius track. Before you do this, M.T.H. **strongly** recommends that you secure the cables with several small pieces of tape or string. If you choose to tape or tie the cables, secure them together just above the boom block assembly on the car's base, just below the snatch block, and just below the boom sheave on the end of the boom. If you use string it will allow the cables to move, however, if you use tape you will need to remove the tape if you wish to raise or lower the hook or boom. (See figure 1)

1. Place the small plastic chock provided into the holes on the crane base, under the boom. (See figure 2)
2. Carefully note the position of the cables running from the body up the boom and stabilize them as described above to keep them from detaching when the boom is folded.
3. Press the small tab that protrudes from under the boom, in the middle, until the latch keeping the boom straight releases. Bend the top half of the boom back toward the car body and prop the boom onto the chock below. (See figures 3 & 4)
4. Secure the cables so that they will not fall onto the track as you run.

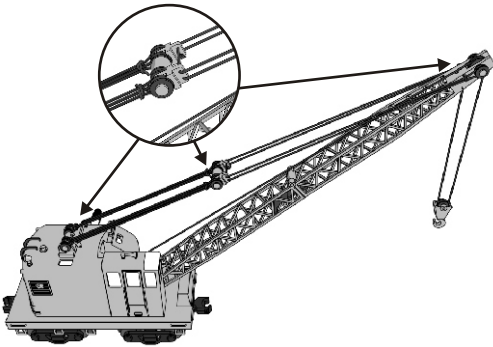

Figure 1. Loosely secure the cables with several small pieces of string.

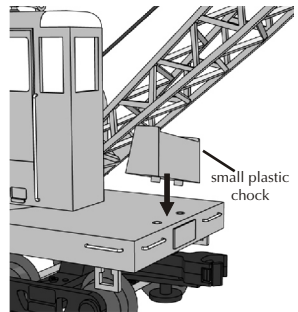

Figure 2. Place the Boom Chock on the crane base

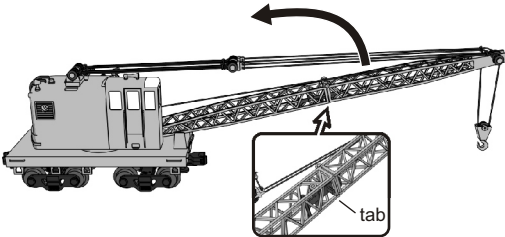

Figure 3. Fold the Boom back by releasing the latch

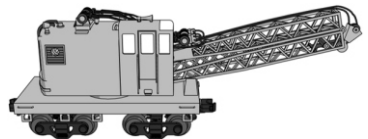

Figure 4. Boom folded and cables secured

### To straighten the boom for use:

- Straighten the boom until the latch that holds it straight clicks back into place.
- **If the cables have come loose, do not start pulling on them, as that can cause further disarray.** If they have simply fallen off the sheaves that allow them to lower and raise the boom/hook, simply realign them as shown and put them around the appropriate sheaves. (see Figure 5)

Once all the cables are threaded over the sheaves look to make sure the cables are straight and do not cross from one side of the car to another. You may need to turn the snatch block over to uncross the cables. If so, adjust the top cables accordingly and double check proper alignment.

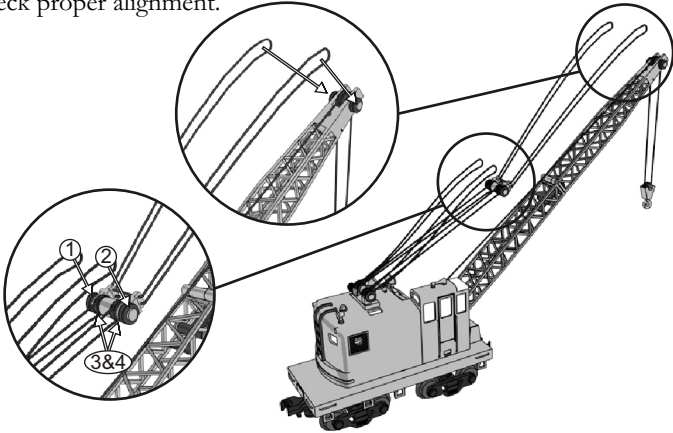

Figure 5. Re-aligning the cables on the sheaves

**If the cables have come very loose** and have lost the proper number of loops, begin by reestablishing the correct number of loops. In addition to the cable that operates the hook and runs the full length of the boom, there should be two loops of cable above the snatch block and four loops below the snatch block, one for each sheave, as shown above. First, align and de-tangle the cables so that you can work with them more easily.

- Thread the cable connected to the hook over the center sheave at the top end of the boom so that the hook hangs below. (see Figure 6)

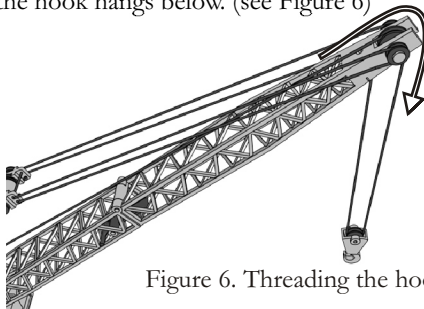
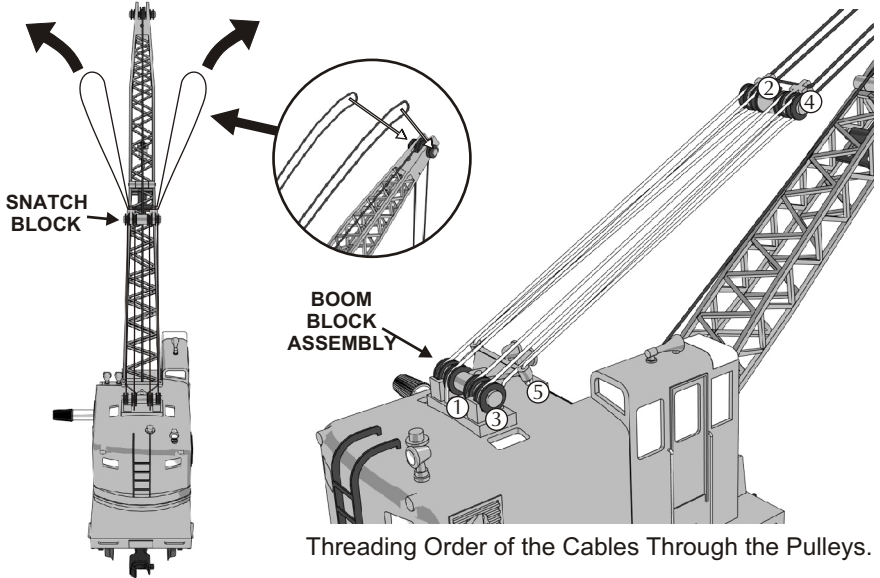

Figure 6. Threading the hook over the center sheave

**To restore two loops from the snatch block to the top of the boom:**

1. Gently pull them equally from both sides of the snatch block. (see Figure 7)
2. Once you have two loops of roughly equal length, make sure the cables are not crossed and thread them back over their sheaves (see Figure 7)

Figure 7. Pulling the cables equally from both sides



**To restore the four loops from the car body to the snatch block:**

1. First thread the two inner loops trapped around the snatch block over the two inner sheaves. You may find that you need to turn the snatch block and tuck the cables under it to get the cables around the snatch block rather than around each other so that you can do this. Re-align the two upper loops
2. At the boom block assembly, pull on the cables at the outer sheaves until you have two additional loops. This will shorten the inner loops you already have; allow the boom to rise if necessary to adjust for the tension in the cables.
3. Thread the two new loops over the two outer sheaves on the snatch block.
4. Once each sheave has a loop of cable threaded through it, examine the cables to ensure that they are straight and not crossing from one side of the car to the other. Uncross them and tuck them around other cables as necessary to prevent tangling. Lower or raise the hook and boom to be sure they are operational.

# Service & Warranty Information

## How to Get Service Under the Terms of the Limited One-Year Warranty

When you suspect an item is defective, please check the operator's manual for standard operation and troubleshooting techniques that may correct the problem. Additional information may be found on the M.T.H. Website. Should you still require service, follow the instructions below to obtain warranty service.

First, e-mail, write, call or fax M.T.H. Electric Trains or a M.T.H. Authorized Service Center (ASC) in your area to obtain Repair Authorization. You can find the list of ASCs on the M.T.H. Website, [www.mth-railking.com](http://www.mth-railking.com). Authorized Service Centers are required to make warranty repairs on items sold *only* from that store; all other repairs may-- or may not be done at the store's own discretion. If you did not purchase the item directly from the ASC, you will need to select a National Authorized Service Center (NASC) or contact M.T.H. Electric Trains directly. NASC Dealers are compensated by M.T.H. to perform warranty service for any customer whose repair qualifies for warranty service. A list of NASC retailers can be located on the M.T.H. Website or by calling 410-381-2580. Should the warranty no longer apply, you may choose either an ASC or NASC retailer to service your M.T.H. Product. A reasonable service fee will be charged.

**CAUTION:** Make sure the product is packed in its original factory packaging including its foam and plastic wrapping material to prevent damage to the merchandise. There is no need to return the entire set if only one of the components is in need of repair *unless otherwise instructed by the Service Center*. **The shipment must be prepaid and we recommend that it be insured. A cover letter including your name, address, daytime phone number, e-mail address (if available), Return Authorization number (if required by the service center, a copy of your sales receipt and a full description of the problem must be included to facilitate the repairs. Please include the description regardless of whether you discussed the problem with a service technician when contacting the Service Center for your Return Authorization.**

Please make sure you have followed the instructions carefully before returning any merchandise for service. Authorized M.T.H. Service Centers are independently owned and operated and are not agents or representatives of M.T.H. Electric Trains. M.T.H. assumes no responsibility, financial or otherwise, for material left in their possession, or work done, by privately owned M.T.H. Authorized Service Centers. If you need assistance at any time email MTH Service at [service@mth-railking.com](mailto:service@mth-railking.com), or call 410 381-2580.

## Limited One-Year Warranty

All M.T.H. products purchased from an Authorized M.T.H. Retailer are covered by this warranty. See our Website to identify an Authorized M.T.H. Retailer near you.

M.T.H. products are warrantied for one year from the date of purchase against defects in material or workmanship, excluding wear items such as light bulbs, pick-up rollers, batteries, smoke unit wicks, and traction tires. We will replace or credit (at our option) any defective item with a manufactured suggested retail price of \$279.95 or less (excluding all motive power and electronic items), if the item is returned to an M.T.H. Authorized Service Center (ASC) or M.T.H. National Authorized Service Center (NASC) within one year of the original date of purchase. For any item with an MSRP greater than \$279.95 (including all motive power and electronics), We will repair, replace or credit (at our option) the defective item without charge for the parts or labor, if the item is returned to an M.T.H. Authorized Service Center (ASC) or M.T.H. National Authorized Service Center (NASC) within one year of the original date of purchase. This warranty does not cover damages caused by improper care, handling, or use. Transportation costs incurred by the customer to ship the product for warranty service are not covered under this warranty.

Items sent for repair must be accompanied by a return authorization number, a description of the problem, and a copy of the original sales receipt from an Authorized M.T.H. Retailer stating the date of purchase. If you are sending this product to an Authorized Service Center, contact that Center for their return authorization.

This warranty gives you specific legal rights, and you may have other rights that vary from state to state. Specific questions regarding the warranty may be forwarded to M.T.H. directly

Service Department  
M.T.H. Electric Trains  
7020 Columbia Gateway Drive  
Columbia MD 21046-1532  
410-381-2580  
[service@mth-railking.com](mailto:service@mth-railking.com)